

# How Fuses Work

## Introduction

Students use electrical devices every day. An essential safety component of any electrical device is the fuse. Demonstrate what it means to “blow a fuse” and show why fuses are important safeguards against electrical fires.

## Concepts

- Electrical circuit
- Fuses
- Ohm’s law
- Short circuit

## Materials (for each demonstration)

Aluminum foil strip, 2 mm × 10 cm

Balloon

Connector cords with alligator clips, 4

Lamp receptacle

Lantern battery, 6-V

Miniature lightbulb, 6-V

Scissors

Support stand and clamp

Tape

## Safety Precautions

*Although latex (in balloons) is considered nonhazardous, not all health aspects of this substance have been thoroughly investigated. Latex may be an allergen. A 6-volt battery is not harmful, but small shocks are possible. Do not leave the short circuit wiring in place for more than 15 seconds. The battery can discharge quickly and the terminals and alligator clips can become very hot if connected for a longer duration. Disconnect the battery immediately once the balloon pops. When the balloon pops, be careful of flying particles. The demonstrator and all observers should wear safety glasses. Wash hands thoroughly with soap and water before leaving the laboratory. Follow all laboratory safety guidelines.*

## Preparation

1. Cut a narrow strip of aluminum foil, 2 mm × 10 cm for each demonstration. *Note:* Cut the aluminum very thin—less than 2 mm wide if possible. The ends may be slightly wider so they do not break when the alligator clips are attached.
2. Screw a 6-V miniature lightbulb into the lamp receptacle.
3. Set up a support stand and clamp. This will allow students a better view of the balloon “fuse.”

## Procedure

1. Blow up a balloon, leaving it slightly underinflated. *Note:* Overinflating the balloon may increase the chance of an unexpected “pop” while completing the circuit or adjusting the foil strip.
2. Tie the open end of the balloon in a knot.
3. Tape a 2 mm × 10 cm strip of aluminum foil to the widest part of the balloon, leaving 2–3 cm of the aluminum strip free at each end (see Figure 1). Make sure the center portion of the foil strip between the two pieces of tape is flat against the balloon.
4. Place the knot of the balloon in the clamp and tighten the clamp to secure the balloon for better viewing.
5. Using three connector cords with alligator clips, connect a 6-V lantern battery, the lightbulb, and the aluminum strip in series (see Figure 2). Be sure the metal of the alligator clips is not touching any part of the balloon.
6. The lightbulb should light, showing the circuit is complete.
7. Instruct students to “cup” their ears with their hands as protection from the loud “pop” of the balloon.
8. Standing away from the balloon, create a short circuit by attaching each end of a fourth connector cord to the clips on the lamp receptacle (see Figure 3). The bulb should go out or become very dim.
9. Make note of the time the short circuit was created. The balloon should burst in a few seconds. *Note:* Do not leave the

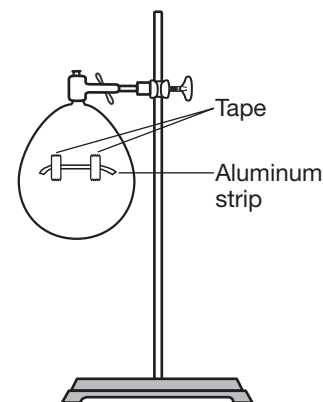

Figure 1.

## How Fuses Work *continued*

short circuit in place for more than 15 seconds. If the balloon does not burst, disconnect the wires from the battery first, and then check to make sure the aluminum strip is flat against the balloon. Adjust if necessary. Repeat steps 5–8.

10. Once the balloon pops disconnect the battery immediately.

11. Show students the broken aluminum strip.

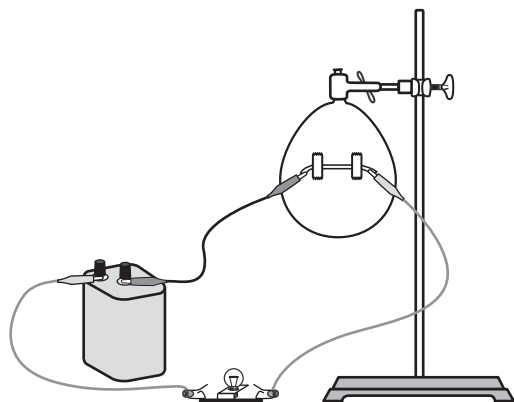

Figure 2.

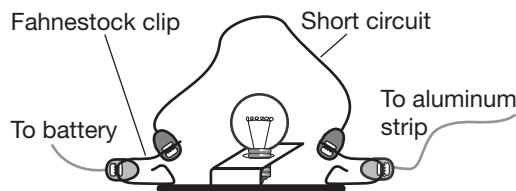

Figure 3.

## NGSS Alignment

This laboratory activity relates to the following Next Generation Science Standards (2013):

### Disciplinary Core Ideas: Middle School

MS-PS2 Motion and Stability: Forces and Interactions

PS2.A: Forces and Motion

PS2.B: Types of Interactions

### Disciplinary Core Ideas: High School

HS-PS2 Motion and Stability: Forces and Interactions

PS2.A: Forces and Motion

PS2.B: Types of Interactions

### Science and Engineering Practices

Asking questions and defining problems

Developing and using models

Planning and carrying out investigations

Analyzing and interpreting data

### Crosscutting Concepts

Patterns

Cause and effect

Structure and function

## Tips

- A size 0 solid rubber stopper may be used to seal the inflated balloon rather than tying a knot. The stoppered end of the balloon can be secured in the clamp.
- When the short circuit is produced, the alligator clips will heat up. If either clip is touching the balloon, the latex may melt in that spot and cause the balloon to pop, instead of the aluminum strip “wire” causing the balloon to pop. While the effect may seem the same, the aluminum strip may not break in the former example.
- Stand away from the balloon when connecting the wire for the short circuit—the balloon may pop very quickly!
- Four 1.5-V batteries connected in series may be used in place of a 6-V lantern battery. Two or three 1.5-V batteries may also work; however, the balloon will most likely take longer than 15 seconds to pop.
- It is important to disconnect the battery immediately after the balloon pops. Even though the circuit is no longer complete when the aluminum strip breaks, if any exposed metal parts of the system touch other metal to complete a circuit, current may flow and cause parts of the circuit to overheat.
- Always wear safety glasses when working with an inflated balloon. Even peeling off a piece of tape to make an adjustment in the aluminum strip may cause the balloon to burst.
- This activity is available from Flinn Scientific as a demonstration kit, *How a Fuse Works* (Catalog No. AP7365).

## Discussion

A fuse (fusible link) is a device designed to stop the flow of current when a circuit overheats. A circuit may get too hot either by

carrying a load greater than it was designed for or by a *short circuit*. A short circuit may occur when wires lose part of their insulation or become frayed and touch each other. The path of the current is shortened, resulting in less resistance in the circuit. Less resistance results in more current flowing through the circuit than was intended. This can cause damage to the circuit from overheating, and may eventually start a fire or cause an explosion.

Electrical devices in a home, business, vehicle, and even handheld devices are protected by fuses. The fuse is part of the circuit it is designed to protect. Most fuses include a filament with a lower melting point than the rest of the wiring in the circuit. When a circuit overload occurs, the filament melts and breaks, creating an open circuit. In this demonstration, the balloon assembly represents the low-melting-point filament. When the short circuit is established, the aluminum strip heats up, melting the balloon. As the balloon bursts, it breaks the thin aluminum strip, interrupting the circuit. To reestablish current, the “blown” fuse must be removed and a new one inserted in its place. Most household circuits today as well as some electrical devices (such as a hair dryer) are protected by a circuit breaker. A circuit breaker causes a temporary interruption to the current flow, and can be reset once the problem in the circuit has been corrected.

### Materials for *How Fuses Work* are available from Flinn Scientific, Inc.

Catalog No.	Description
AP7365	How a Fuse Works—Demonstration Kit
AP1429	Lantern Battery, 6-V
A0019	Aluminum Foil, Household Type
AP6035	Lamp Receptacles, Economy Choice
AP6321	Connector Cords with Alligator Clips
AP9257	Miniature Lightbulb, 6.15-V

Consult your *Flinn Scientific Catalog/Reference Manual* for current prices.