

P.O. Box 219 • Batavia, IL 60510  
(800) 452-1261 • Fax (866) 452-1436  
www.flinnsci.com • E-mail: flinn@flinnsci.com  
© 2014 Flinn Scientific, Inc. All Rights Reserved.

**FLINN**  
SCIENTIFIC, INC.  
"Your Safer Source for Science Supplies"

Catalog No. AP6302

Publication No. 6302

# Simple Circuits

## Student Laboratory Kit

### Introduction

The ability to use electrical energy to do work has significantly changed the way we live. Controlling electrical energy has given us the ability to light our homes with the flip of a switch, talk to relatives hundreds of miles away, and launch a spacecraft to the moon and return it safely back to Earth, among other things. The first step to understanding electricity is by studying the behavior of simple circuits. These laboratory experiments will familiarize you with how simple series and parallel circuits operate.

### Concepts

- Series circuits
- Parallel circuits
- Circuit diagrams

### Background

Work in an electrical system is done by moving negatively charged particles called *electrons*. The movement of electrons in an electrical system is called *electric current*. Electric current can not be seen because electrons are too small to be viewed, but its effect can be observed and measured. The motion of electrons traveling down a wire can be compared to the movement of water in a hose. Just like with water flowing through a hose, energy must be supplied to the electrons before they will move in a wire and provide energy to do work. The energy can be supplied by chemical means, such as with a battery, or by mechanical means, such as with a waterwheel in a river turning a generator. The amount of energy supplied to each electron passing through the electrical system is called *voltage*. Voltage can be compared to the potential energy (stored energy) of water that is contained in a water tower. Work is done on water to lift it into a water tower, giving water potential energy. When the water is released from the tower, it will provide the same amount of energy that was initially put into it. The water can not provide additional energy above its initial potential energy. The potential energy is directly related to the height of the water tower. The taller the water tower, the more energy the running water can supply at the bottom. Voltage in an electrical system is similar to the height of the water tower. The negative terminal of a battery can be considered the top of a water tower where all the electrons have accumulated and are ready to flow down a wire. The positive terminal can be considered the bottom of the water tower. The negative electrons are attracted to the positive terminal, according to the fundamental principle that unlike electric charges attract each other. In order for the electrons to move from the high point (negative terminal) to the low point (positive terminal) and do useful work, there must be an unbroken path between the terminals of the power supply that will allow the electrons to flow. This unbroken path is called a *circuit*. When the path is broken, the circuit is *open*, and no electricity will flow.

In a simple direct current (DC) circuit, a load (also called appliances or resistors, e.g., lightbulbs, motors, clocks, etc.), is connected between the terminals of a power supply with conductive wires. The electrons travel from the negative terminal through the load, providing energy to operate it, and stop at the positive terminal. For an incandescent lightbulb, the energy from the flowing electrons causes the tungsten filament to heat up and produce visible light. The amount of work done on each load is determined by the *voltage drop* across it. The voltage drop is the energy removed from the electrical system per unit of charge passing through the load. The total voltage drop of all the loads in an electrical circuit will always be equal to the total voltage provided by the electrical power source. If a 9-V battery is connected to a circuit, the voltage drop through the entire circuit will always be 9 volts—no more, no less. For this to occur, it means that one load in a multiple load circuit cannot consume all the energy from the power source. The energy distributes itself throughout all the loads depending upon how many loads there are and how they are connected in the circuit. The voltage drop across an individual load in a circuit depends on its *resistance* and the amount of current that travels through it. Resistance is a measure of how difficult it is for the electrons (current) to travel through a load. Generally speaking, the resistance of load is constant. Therefore, since the total voltage and resistance of each load are constant in a simple DC circuit, the total current through each load (and therefore the voltage drop through each load) will depend on how the loads are connected in the circuit. There are two ways to connect loads in simple DC circuits—in series and in parallel. Table 1 shows common symbols used in circuit diagrams to represent components in a circuit.

Symbol	Circuit Component
	Load or resistor (general)
	Lightbulb
	Battery; multiple batteries
	Switch

**Table 1.**

In a series circuit (see Figure 1), all of the loads are connected together in a line from the negative terminal to the positive terminal of the electric power supply. There is only one path for the current to travel and therefore the current is the same through each load. The total current in the circuit, and therefore the current flowing through each load, depends on the total resistance of the entire series circuit. The more loads that are connected in series, the higher the total resistance. The higher the resistance, the lower the total current traveling through the circuit and through each load. Since every load in a series circuit will receive the same current, the voltage drop across each load in a series circuit depends on its resistance.

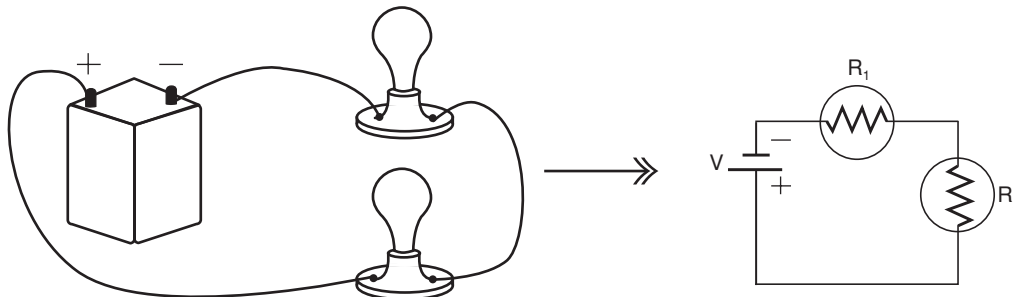

**Figure 1.** Resistors in series

Appliances connected in parallel are coupled by separate wire branches that connect each appliance directly to the terminals of the power source (see Figure 2 on page 3). Since each load is connected directly between the terminals of the power supply, the voltage drop through the load will equal the total voltage from the power supply. This is true for all the loads that are connected in parallel. Each load produces the same voltage drop, equal to the total voltage from the power supply, and independent of its resistance. However, the current in a parallel circuit can vary through each load. Since there are multiple pathways for the current to travel in a parallel circuit, the current that flows through each load will vary depending on its resistance. The higher the resistance, the lower the current that will travel through it. As a result of having multiple current pathways, the effective resistance of a complete parallel circuit is lower than the individual load resistances. The resistance of the loads has not changed, but the arrangement of the loads allows the current to travel more efficiently, and thereby decreases the effective resistance of the entire parallel circuit. The effective resistance of a parallel circuit is always lower than the lowest-resistant load in the circuit. Since the effective resistance is lower, the total current that is drawn from a power supply, or battery, and flows through a parallel circuit will increase as more loads are added in parallel.

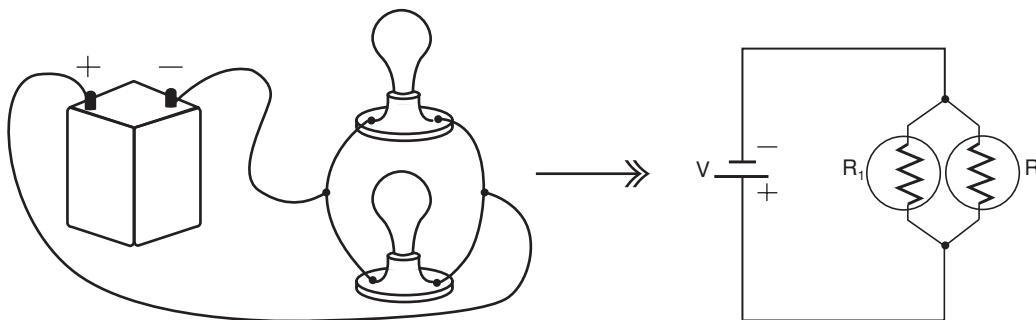

**Figure 2.** Resistors in parallel

In the following experiments on series and parallel circuits, observe how the brightness of the lightbulbs varies as the number of lightbulbs increases, and as the connections with the batteries change. The brightness of the lightbulb is a quantitative measure of the amount of current traveling through the lightbulb.

## Materials

Batteries, 3- to 6-V equivalent in battery holder

Connector cords with alligator clips, 8

Lamp receptacles, 3

Miniature lightbulbs, 3

Pins (coupler for parallel circuit), 2

## Safety Precautions

*Please follow normal laboratory safety guidelines.*

## Procedure

### Series Circuits

1. Refer to the circuit diagrams shown in Figure 3 below.
2. Connect the connector cords, lightbulb and batteries together according to Figure 3a. The alligator clips connect directly to the lamp receptacle terminals and the terminals of the battery holder.
3. Observe the lightbulb. Does it glow? How brightly? Record your observations in the Simple Circuits Worksheet.
4. Open the circuit by disconnecting one clip from a battery terminal.
5. Add another lightbulb to the circuit according to Figure 3b.
6. Reconnect the battery and observe both lightbulbs light up. Does either one glow as brightly as the original single lightbulb? Record your observations in the worksheet.
7. Open the circuit by disconnecting one clip from a battery terminal.
8. Add a third lightbulb to the circuit according to Figure 3c.

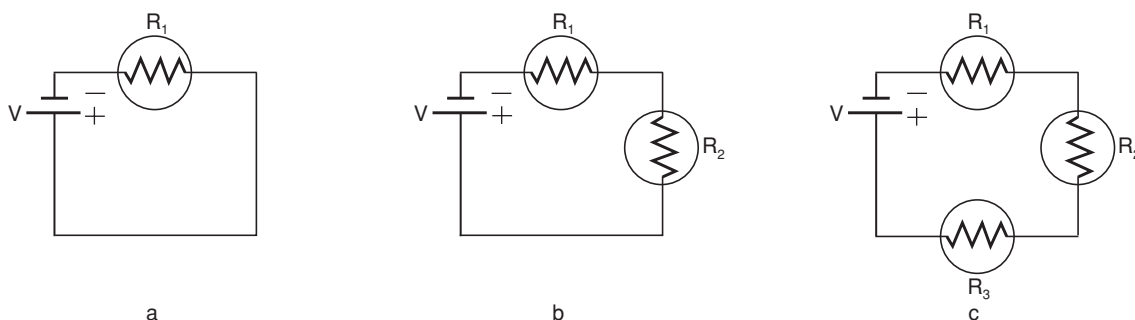

**Figure 3.** Lightbulbs in Series.

9. Reconnect the battery and observe the three lightbulbs. Do the lightbulbs light up? How bright are the bulbs compared to the first experiment (one bulb) and second experiment (two bulbs in series)? Record your observations in the worksheet.
10. Disconnect one alligator clip from the second lightbulb to create an open circuit. What happens to the lightbulbs? Record your observations in the worksheet.

## Parallel Circuits

11. Refer to the circuit diagrams shown in Figures 4 and 5 below.
12. Connect the connector cords, lightbulbs, battery, and couplers together according to Figure 4a.
13. Observe the lightbulbs. Do they glow? How brightly compared to the original single lightbulb? Record your observations in the Simple Circuits Worksheet.
14. Open the circuit by disconnecting one clip from a battery terminal.
15. Add another lightbulb to the circuit according to Figure 4b.
16. Reconnect the battery and observe the three lightbulbs. Do they glow as brightly as the original lightbulb? How does the brightness compare to two lightbulbs connected in parallel? Record your observations in the worksheet.
17. Disconnect one alligator clip from one of the lightbulb receptacles. Do the lightbulbs turn off? Do any lightbulbs remain on? If so, has their brightness changed? Record your observations in the worksheet.
18. Reconnect the clip, and then disconnect a clip from a different lightbulb. What happens? Record your observations in the worksheet.
19. Reconnect all the lightbulbs in parallel again so that all three are glowing (Figure 4b). Then, disconnect both leads connected to one lightbulb. Touch these two leads together to create a *short circuit*. See Figure 4c for a diagram of the circuit. What happens to the other two lightbulbs? Record your observations in the worksheet.
20. Answer the *Post-Lab Questions* on page 2 of the Simple Circuits Worksheet.

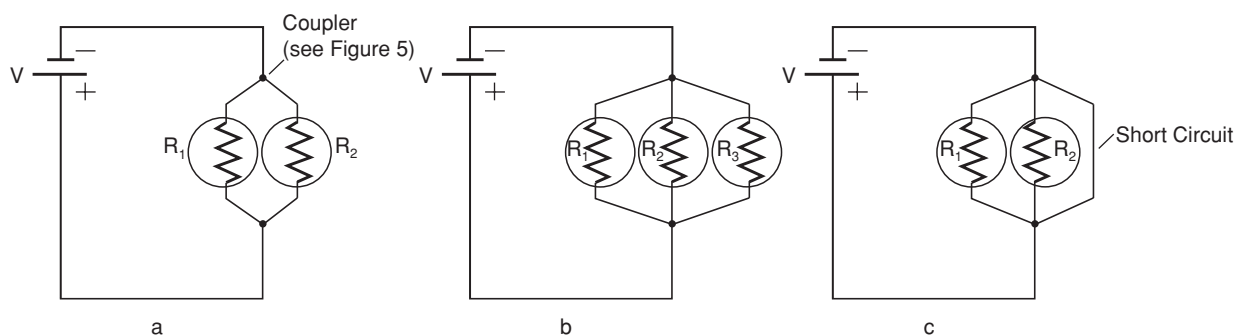

Figure 4. Lightbulbs in Parallel.

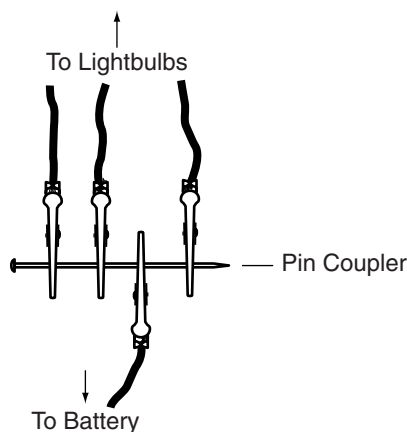

Figure 5. Pin coupler arrangement for parallel circuit connection.

## Disposal

Consult your instructor for proper storage guidelines for the connector cords and other components.

# Simple Circuits Worksheet

## Series Circuit Observations

One Lightbulb:

Two Lightbulbs:

Three Lightbulbs:

Open Circuit:

## Parallel Circuit Observations

Two Lightbulbs:

Three Lightbulbs:

Open Circuit:

Two Lightbulbs and One Short Circuit:

# Simple Circuits Worksheet, Cont'd.

## Post-Lab Questions

1. Which circuit design produced the brightest lightbulbs? Relate this to the amount of current flowing through each lightbulb.
2. What happened when all three lightbulbs were connected in series? Why did this occur?
3. Is there more resistance in the series circuit or the parallel circuit? How can you tell?
4. What is one advantage of a series circuit? What is one disadvantage?
5. What is one advantage of a parallel circuit? What is one disadvantage?
6. What happened with the two parallel-connected lightbulbs and the short circuit?
7. Is it better to have a string of lights, such as Christmas-tree lights, connected in series, or parallel? Explain.

# Teacher's Notes

## Simple Series and Parallel Circuits

### Materials Included in Kit

Connector cords with alligator clips, 32

Lamp receptacles, 12

Miniature lightbulbs, 3.7 V, 15

Pins (coupler for parallel circuit), 8

### Additional Materials Needed (for each lab group)

Batteries, 3- to 6-Volt equivalent (two D-cells in a D-cell holder, or one 6-Volt cell can be used.)

### Safety Precautions

*Please follow normal laboratory safety guidelines.*

### Disposal

The materials should be saved for future use.

### Connecting to the National Standards

This laboratory activity relates to the following National Science Education Standards (1996):

#### ***Unifying Concepts and Processes: Grades K–12***

Systems, order, and organization

Evidence, models, and explanation

Constancy, change, and measurement

#### ***Content Standards: Grades 5–8***

Content Standard A: Science as Inquiry

Content Standard B: Physical Science, transfer of energy

#### ***Content Standards: Grades 9–12***

Content Standard A: Science as Inquiry

Content Standard B: Physical Science, motions and forces, conservation of energy and increase in disorder, interactions of energy and matter

### Tips

- Enough materials are provided in this kit for 8 students working in pairs, or 4 groups of students. All materials are reusable. This laboratory activity can reasonably be completed in one 50-minute class period.
- Students should refer to their textbooks for further information regarding electric circuits.
- To further extend the level of instruction, voltmeters and ammeters can be used on each circuit to determine the voltage drop and current flowing through each lightbulb for each circuit setup.
- To extend the lifetime of the lightbulbs, make sure students connect the circuits for short (less than 15 seconds) time increments. This is especially important during the parallel circuit experiments since more current will travel through the lightbulbs.

## Teacher's Notes *continued*

### Sample Data

#### Series Circuit Observations

One Lightbulb:

*Bulb glows brightly.*

Two Lightbulbs:

*Both lightbulbs glow, but less brightly than a single lightbulb connected to the battery.*

Three Lightbulbs:

*All three lightbulbs glow very dimly. Can only see a tiny glow from each lightbulb filament.*

Open Circuit:

*Disconnecting one lightbulb results in all three lightbulbs turning off.*

#### Parallel Circuit Observations

Two Lightbulbs:

*Each lightbulb glows nearly as brightly as a single lightbulb connected to the battery.*

Three Lightbulbs:

*Each lightbulb glows slightly less brightly than two lightbulbs connected in parallel.*

Open Circuit:

*When one lightbulb is disconnected from the circuit, the other two glow slightly brighter. It does not matter which lightbulb is disconnected. When two lightbulbs are disconnected, the third lightbulb glows slightly brighter; the brightness is close to that of a single bulb connected to the battery.*

Two Lightbulbs and One Short Circuit:

*When the circuit is shorted, the two remaining lightbulbs glow very dimly or not at all.*

#### Answers to Post-Lab Questions

1. Which circuit design produced the brightest lightbulbs? Relate this to the amount of current flowing through each lightbulb.

*The single lightbulb connected to the battery glowed the brightest. This lightbulb had the most current flowing through it.*

2. What happened when all three lightbulbs were connected in series? Why did this occur?

*When the three lightbulbs were connected in series, they were barely glowing. They did not glow brightly because the current traveling through them was very low. The resistance of the three lightbulbs in series was high and this lowered the total amount of current in the circuit and the lightbulbs did not receive the energy to glow brightly.*

3. Is there more resistance in the series circuit or the parallel circuit? How can you tell?

*There is more resistance in a series circuit than a parallel circuit. The parallel circuit lightbulbs glowed brighter than the lightbulbs in series meaning more current traveled through them. The amount of current that travels through the lightbulbs is inversely related to the total resistance. The less resistance, the more current and the brighter the lightbulbs.*

4. What is one advantage of a series circuit? What is one disadvantage?

*One advantage of a series circuit is that the circuit uses less current to light the lightbulbs because of the higher resistance. Less current means the circuit is safer, the battery will last longer (draining current reduces the life of the battery), and the circuit will not blow a fuse as readily. The circuit can be easily turned off by disconnecting any part of it. One disadvantage of a series circuit is that when one lightbulb goes out, they all go out. Another disadvantage is that adding more loads lowers the current in all the connected loads and this can decrease their performance.*



## Teacher's Notes *continued*

5. What is one advantage of a parallel circuits? What is one disadvantage?

*One advantage of a parallel circuit is that when one lightbulb goes out, the others remain lit. Another advantage is that there is continued performance of appliances when one is added to or removed from the circuit. A disadvantage is that more current is drained from the power source with the addition of a new load. This current drain could cause a fuse to blow if there is enough heat generated. Another disadvantage is that the voltage rating on the appliances has to be able to handle the voltage of the power source.*

6. What happened with the two parallel-connected lightbulbs and the short circuit?

*The lights dimmed because resistance in the shorted wire was very small so most of the current traveled through this branch, instead of through the more resistant lightbulb branches. Since most of the current was taken away from the lightbulb branches, the lightbulbs became much dimmer. [A short can cause a problem in a circuit because it can drain all the power from a power supply. Since all the current flows through the short, it can also cause a large amount of heating which can lead to a fire.]*

7. Is it better to have a string of lights, such as Christmas-tree lights, connected in series, or parallel? Explain.

*A string of lights in parallel would have the advantage of not going out when one lightbulb goes out in the series. However, a string of lights in parallel would also draw a large amount of current that may blow a fuse. Also, the voltage rating on each lightbulb would have to match the voltage rating of the power supply (120 V for a lightbulbs connected to an ordinary wall outlet). A series circuit would draw less current and would be safer. [Generally, a string of lights are connected in series and parallel. Lights connected in series are combined in parallel with another string of lights in series. This decreases the amount of current needed, and also prevents a search through all the lightbulbs if one lightbulb burns out. Only one section of whole string of lights would need to be checked if one lightbulb is out.]*

### **The Simple Circuits—Super Value Laboratory Kit is available from Flinn Scientific, Inc.**

Catalog No.	Description
AP6302	Simple Circuits—Super Value Laboratory Kit
AP1425	Battery, 1.5-Volt, D-Cell
AP1429	Battery, 6-Volt, Lantern
AP9275	Battery Holder, D-Cell, Double

Consult your *Flinn Scientific Catalog/Reference Manual* for current prices.